

# EMX 10 F000

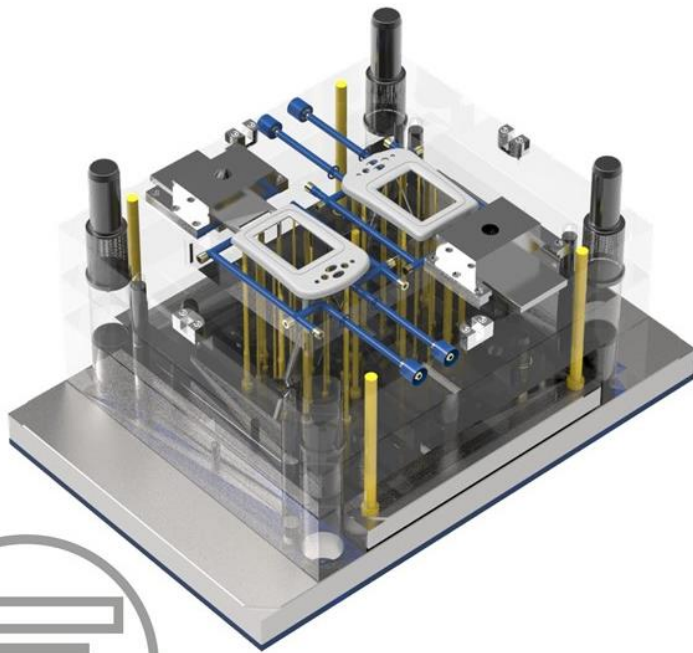

## What's New?

- New Features
- Components



# EMX 10 F000

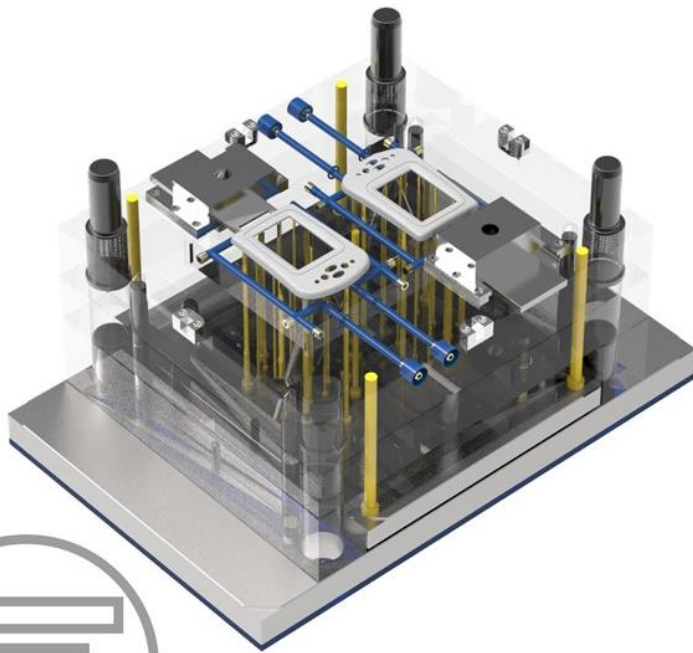

What's New?

- New Features
- Components



# 1. Improved EMX Ribbon

- New Design
- Improved Workflow

## New Session

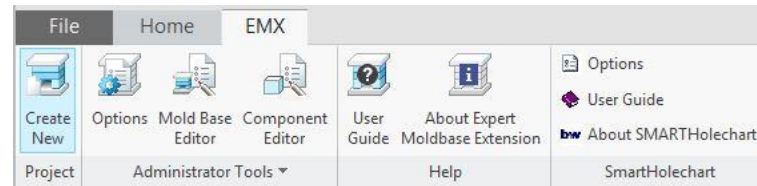

## EMX Assembly

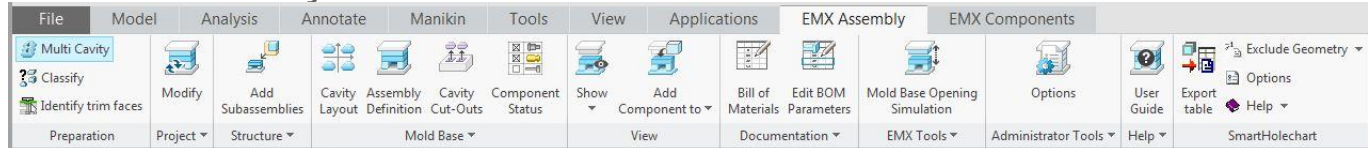

## EMX Components

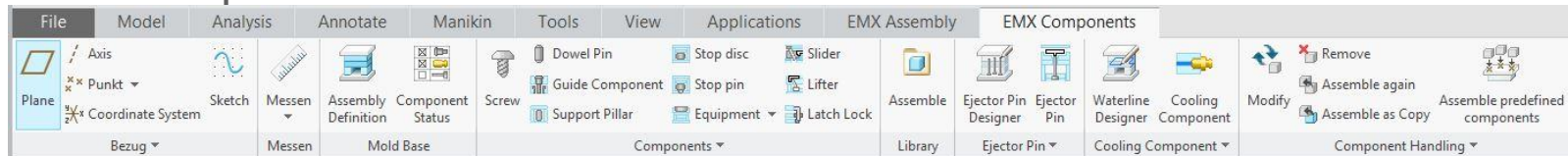

## EMX Manufacturing



## EMX Part Mode

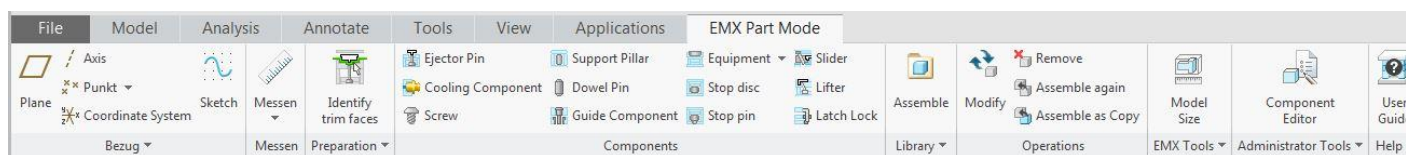

# 1. Improved Workflow

## Preparation in Manufacturing Mode

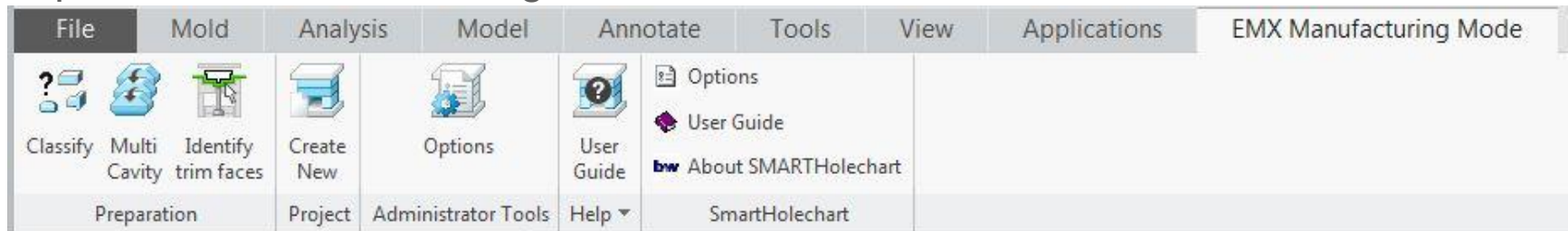

- 1.
- 2.
- 3.
- 4.

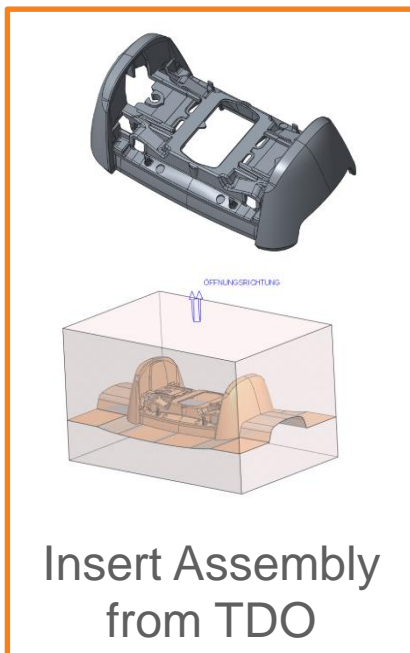

1. Classify Assembly
2. Multi Cavity Assemblies
3. Identify Trim Faces (Enhanced)
4. Create new Project

# 1. Improved Workflow

## Mold Base in Assembly Mode

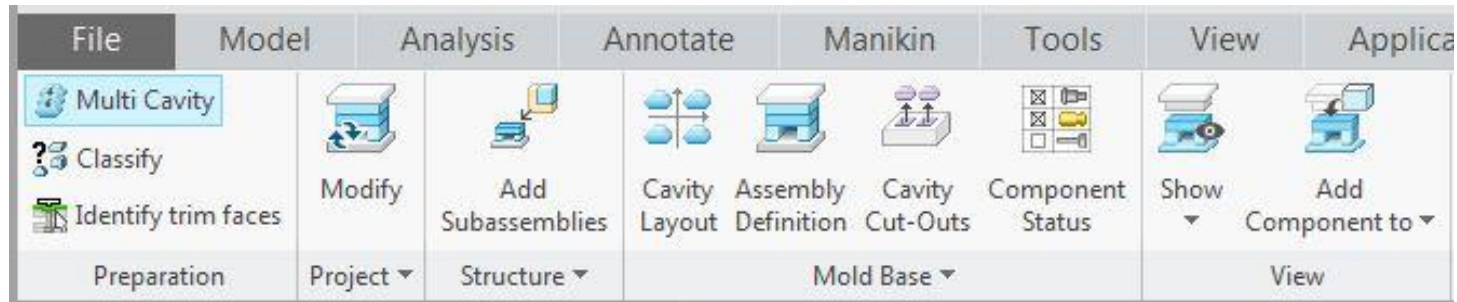

- 1.
- 2.
- 3.
- 4.
- 5.

1. Change Project
2. Set up Structure, Sub Assemblies (Enhanced)
3. Define Cavity Layout (NEW)
4. Define Mold Base(Enhanced)
5. Create Cavity Cuts (NEW)

# 1. Improved Workflow

## Assembly Mode Part 2



- 1.
- 2.
- 3.
- 4.
- 5.
- 6.

1. Components Status

2. View

3. BOM

4. EMX Tools

5. Admin Tools:

EMX Options, Component Editor (**NEW**),  
Mold Base Editor

6. Help and Info About

7. Smart Holechart (**New Version 10.0**)

# 1. Improved Workflow

## EMX Components Part 1

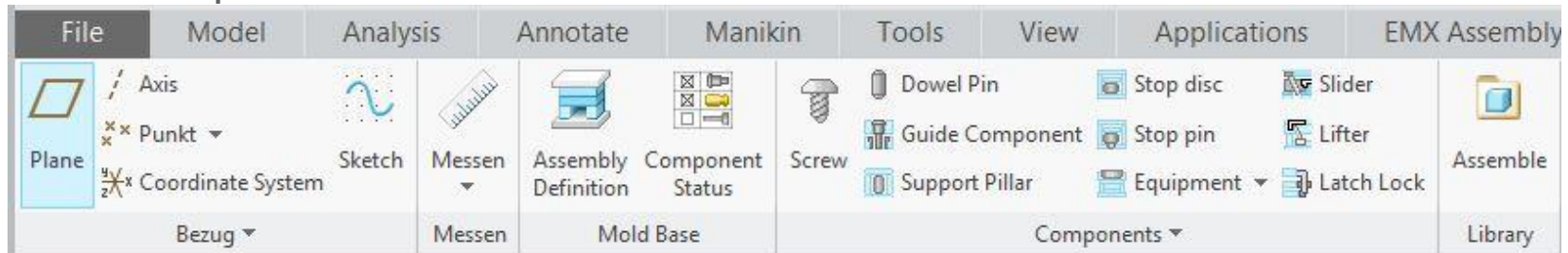

1.

2.

3.

4.

1. Datums und Measure (NEW)

2. Mold Base Definition und Component Status (NEW)

3. Assemble Components: All Types in 1 Group

4. Library Parts

# 1. Improved Workflow

## EMX Components Part 2

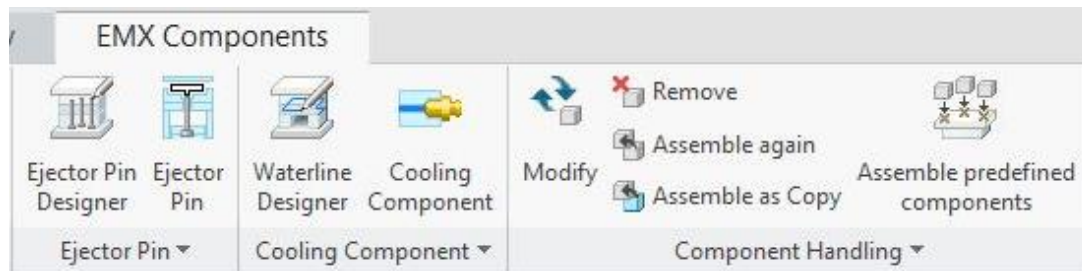

1.

2.

3.

1. Ejector Pins: Definition via Component Dialog or Ejector Pin Designer (**NEW**)
2. Cooling: Definition vis Component Dialog or Waterline Designer
3. Component Handling (**NEW**) , Predefined Components



## 2. Identify Trim Faces

---

### In EMX 9:

Hidden in EMX Components → Ejector Pin

### Now:

Ribbon Group EMX Assembly → Preparation

### Function:

Mark Surface Quilt as Trim Surfaces for Ejector Pins and Lifters

### Effect:

Don't trim via TDO Feature

Use Solidify instead



➔ More stable. Trimming is also possible when ejector cross-section exceeds the model volume

# 3. Enhanced Sub Assemblies

## New in EMX 10:

Assign function to subassembly

Subassembly

123234324

Subassembly Data

Name: 1232343\_SUB\_01

Prefix: 1232343

Postfix: 456

subasm\_function: Assembly

Templates

Copy Drawings

Copy Reports

Parameter

Parameter Name	Value	Default Value
POS	?	?
QTY	1	1
PARTNAME	1232343_SUB_01	1232343_SUB_01
PARTID	1	1
BOM_NAME	Subassembly	Subassembly
SUPPLIER	-	-

OK Cancel

1. Moving Half
2. Fix Half
3. Ejector Pins

### 3. Enhanced Subassemblies

Main assembly with 3 subasms and assigned functions

1. Moving Half
2. Fix Half
3. Ejector Pin

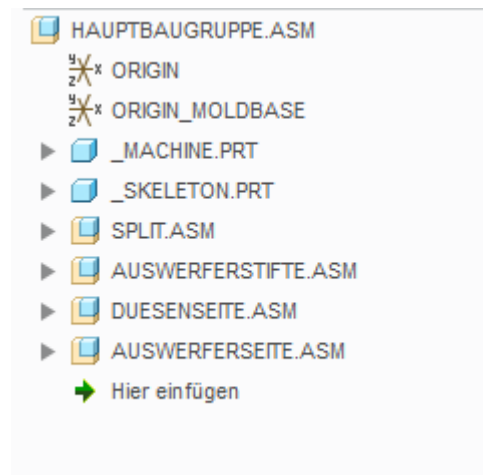

- Automatic pre-selection of MH/FH subasms when assembling from Mold Base Definition Dialog
- Automatic pre-selection for ejector pins

# 4. Cavity Layout Dialog

## Simplified Placement of Insert Assemblies

- Define cavity pattern
- Load multiple insert assemblies
- Individual placement to cavity coordinate systems
- Assemble to main and sub assemblies
- Pattern insert assemblies
- 3D Preview

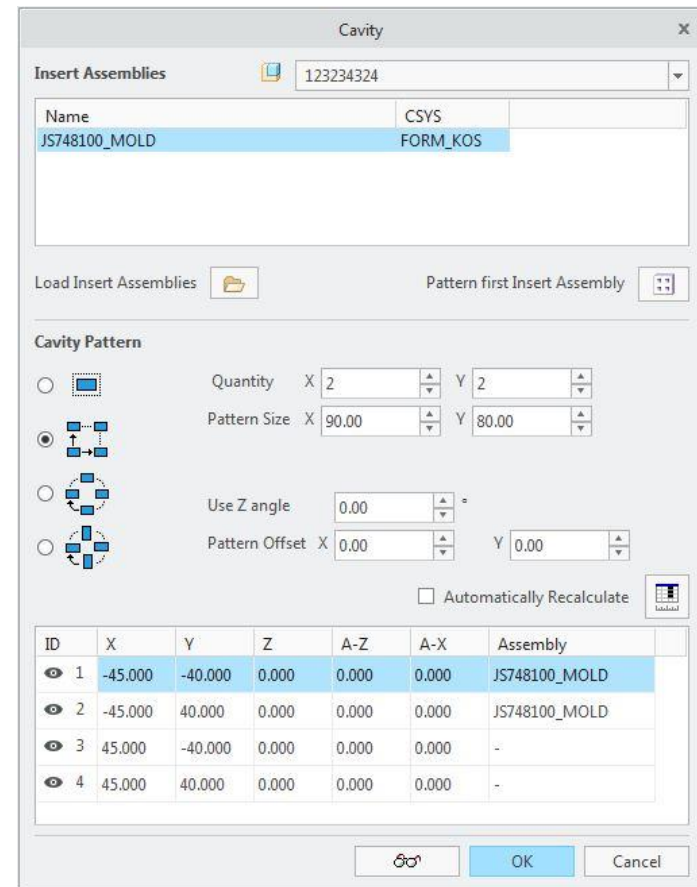

## 5. Cavity Cutout Dialog

### Individual Dialog for Cavity Cutouts

- Functionality as known
- Cutout Types as known

**New:** 3D Preview

**Cavity**

**Cavity Size**

+X 45.000

-X 45.000

+Y 30.000

-Y 30.000

+Z 20.000

-Z 35.000

**Cavity Cutout**

Cut Depth MH 35.000

Cut Length MH 90.000

Cut Width MH 60.000

Cut Depth FH 20.000

Cut Length FH 90.000

Cut Width FH 60.000

With Mouse Ear



Cut Radius 0.000

OK Cancel

## 6. New Component Handling

	EMX 9	EMX 10
Ribbon	Delete Modify As Copy Reassemble  For each Component Type → Redundant	Delete Modify As Copy Reassemble  1x for all Component Type → Looks much better
RMB	Only Delete Modify	All Functions Delete Modify As Copy Reassemble

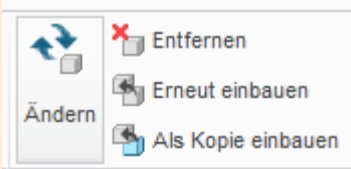
# 6. New Component Handling

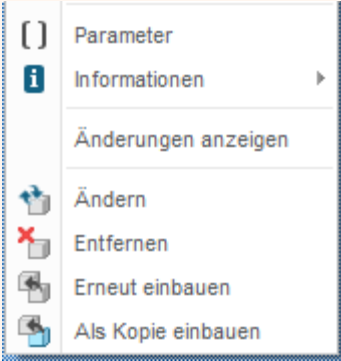
	EMX 9	EMX 10
<p>Ribbon</p>	 <p>The EMX 9 ribbon interface features a grid of buttons labeled 'Definieren' (Define) for various components. Each button includes a small icon of the component and a red 'X' icon, indicating a limitation or error state. The components shown include a light fixture, a pipe, a cooling channel, a fan, a valve, a pump, and a motor. The 'Definieren' label is repeated for each component type.</p>	 <p>The EMX 10 ribbon interface shows a context menu for a component. The menu includes the following options: 'Ändern' (Change) with a circular arrow icon, 'Entfernen' (Remove) with a red 'X' and trash icon, 'Erneut einbauen' (Reinstall) with a trash and plus icon, and 'Als Kopie einbauen' (Install as copy) with a plus and copy icon.</p>
<p>Rechte Maus</p>	 <p>The EMX 9 right-click context menu includes the following options: 'Parameter' with a square icon, 'Informationen' with an information icon and a right-pointing arrow, 'Änderungen anzeigen' (Show changes), 'Komponente ändern' (Change component) with a trash and plus icon, and 'Komponente entfernen' (Remove component) with a red 'X' and trash icon.</p>	 <p>The EMX 10 right-click context menu includes the following options: 'Parameter' with a square icon, 'Informationen' with an information icon and a right-pointing arrow, 'Änderungen anzeigen' (Show changes), 'Ändern' (Change) with a circular arrow icon, 'Entfernen' (Remove) with a red 'X' and trash icon, 'Erneut einbauen' (Reinstall) with a trash and plus icon, and 'Als Kopie einbauen' (Install as copy) with a plus and copy icon.</p>

# 7. Ejector Pin Designer

 Dynamic Definition of Ejector Pins

New Main Feature in EMX 10

- 1. Place Ejectors with 2D Preview
- 2. Place to Fix Half and Moving Half
- 1. Supports 2nd ejector package
- 2. Assemble to all sub asms

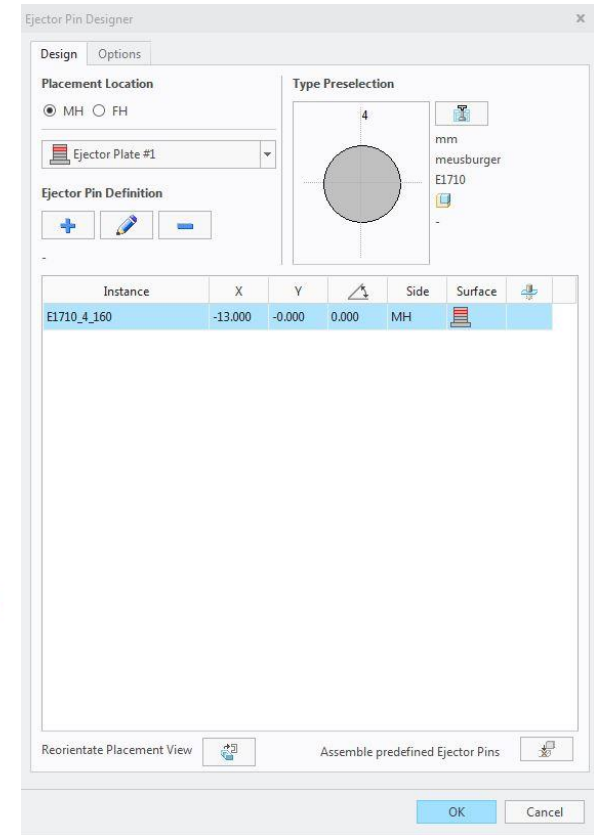
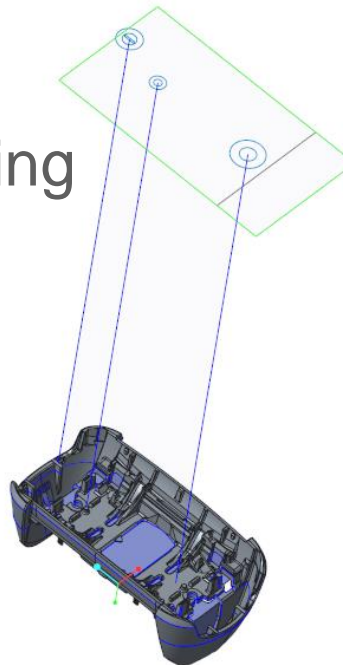



# 8. New Data Structure

Migration from `comp_data.txt` & `udf_data.txt` to `*.dat` Files

In **EMX 10** each component an individual `*.dat` file will be shipped. This file contains all required information to handle:

- a) The component data (assembly constraints, nominal values, instances, etc.)
- b) The entire cut-information (UDFs , UDF options, etc.)

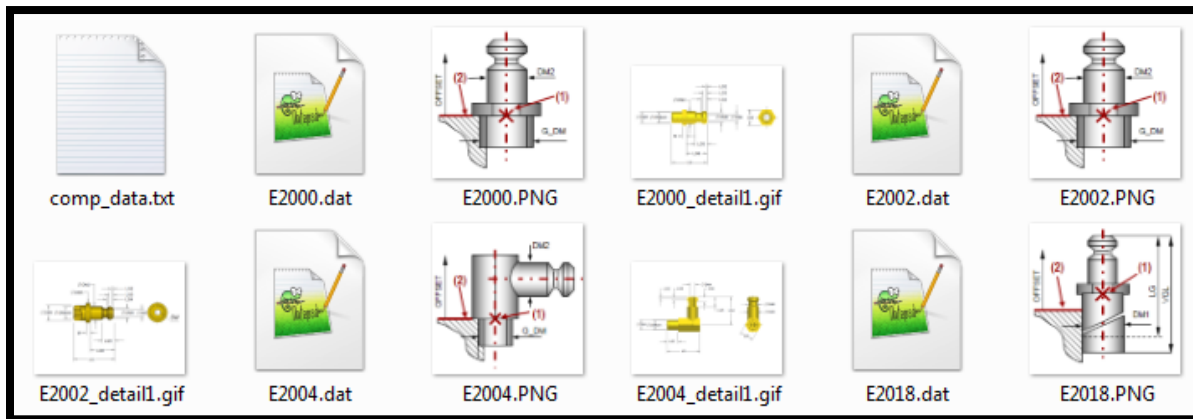

## 9. Convert to EMX 10 Data Structure

Conversion of old comp\_data.txt files can be done **step by step**

- Open EMX → Administrator Tools  
→ **Component Editor**



- Select Button **Split comp\_data.txt file**

- Select a EMX 9 formatted **comp\_data.txt** file in File Open Dialog

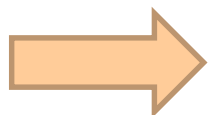

Splitting process is triggered

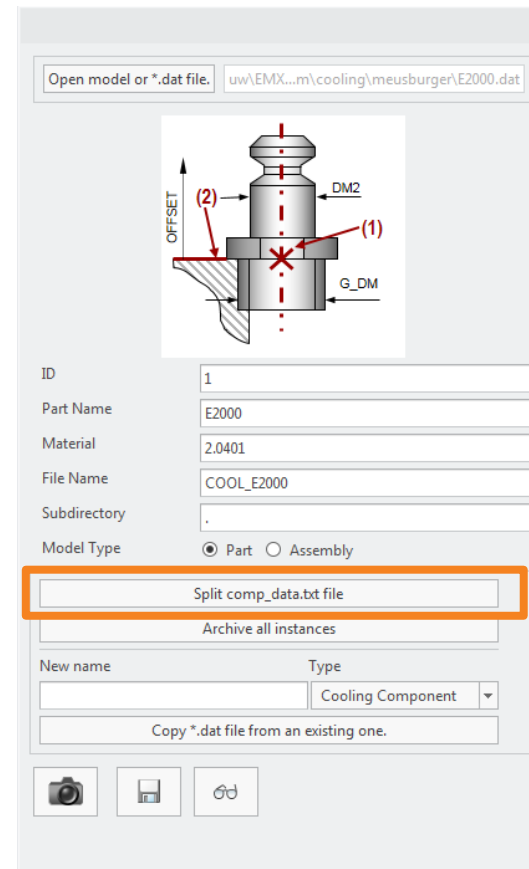

# 10. Facelift for new Component Editor

Conversion of old comp\_data.txt files can be done **step by step**

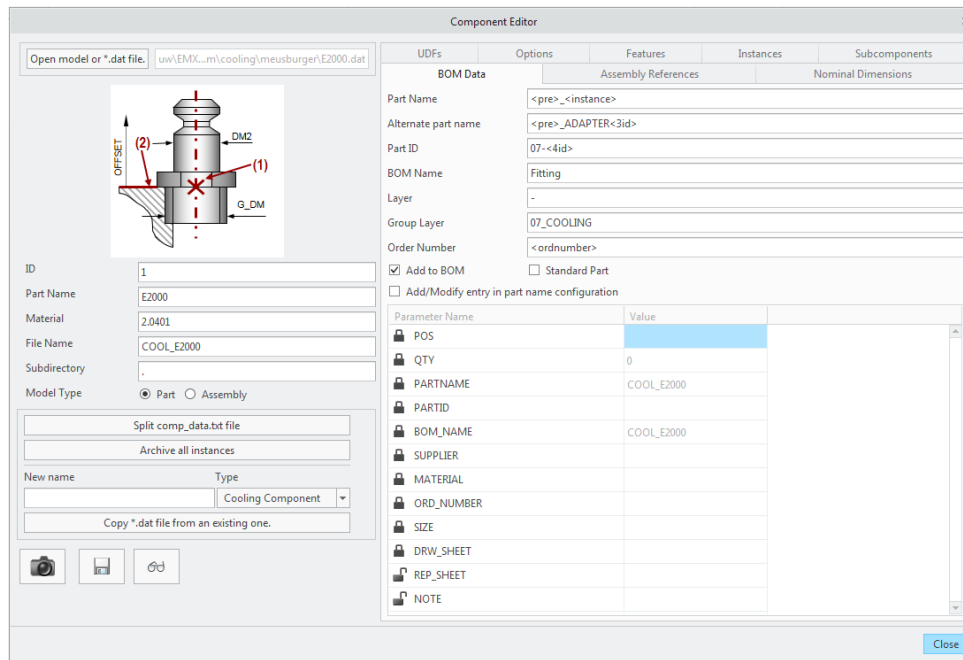

New Features:

- Copy Component from existing template
- Work on UDF cutout information
- Archive all instances from a component

# 10. New EMX Help Center

EMX 10 comes with the **new EMX Help Center**

- Handy Search functionality
- What's new Videos

[Back to top](#)

## 11. Smart Holechart 10.0

---

### Integrated new Version in EMX 10

- Collision Tables
- easy UDF Recognition
- Replace existing Tables
- Adapt Number of Table Columns during Refresh
- Direction-depended Bore Definition
- Automatic creation of Point/Axis in Bore Center
- Use Tolerances (e.g. H7) as criteria for bore types
- Man more Options

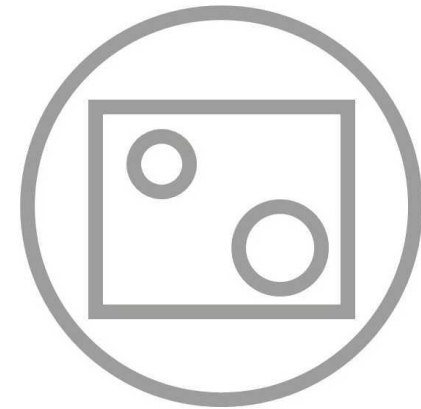

## 11. Smart Holechart 10.0

---

### SHC – Default EMX Configuration

- Smart Holechart 10 comes with a default EMX - adapted configuration
- UDFs and Holes created by EMX can be recognized easily



# 12. Placement of BOM Balloons

## Improvements

- Functions to RMB
- Multiple Selection and Placement in a Loop
- Place Balloon multiple times for summarized components
- New Design

The image shows a BOM table titled 'Stückliste' and a technical drawing of a mechanical assembly with balloons numbered 1 through 6.

E...	V...	MODELL	POS	QTY	(V) PARTNAME
		BALL_CAV_PLATE_FH001	1	1	BALL_CAV_PLATE_FH001
		B...		1	BALL_CAV_PLATE_MH001
		B...		1	BALL_RISERS_R_MH001
		B...		1	BALL_RISERS_L_MH001
		B...		1	BALL_CLP_PLATE_MH001
		B...		1	BALL_CLP_PLATE_FH001
		B...		1	BALL_EJRET_PLATE_MH001
		BALL_EJBASE_PLATE_MH001	8	1	BALL_EJBASE_PLATE_MH001
		BALL_E1000_22_56_35	9	4	BALL_E1000_22_56_35
		BALL_E1160_30_80	10	4	BALL_E1160_30_80
		BALL_E1100_22_56	11	4	BALL_E1100_22_56
		BALLON_PLACEMENT	12	1	BALLON_PLACEMENT
		BALL_MACHINE	13	1	BALL_MACHINE
		BALL_SKELETON	14	1	BALL_SKELETON

The technical drawing below the table shows a cross-section of a mechanical assembly. Six balloons are placed on the drawing, numbered 1 through 6, pointing to various components. Balloons 1, 2, 3, and 5 are at the top, while balloon 6 is at the bottom. A context menu is visible over the BOM table, listing actions like 'Stücklistennummer hinzufügen', 'Stücklistennummer entfernen', 'Stücklistenparameter editieren', 'Ausschneiden', 'Einfügen', and 'Elemente anzeigen/ausblenden'.

## 12. Placement of BOM Balloons

### Improvements

- Place same balloon of component multiple times in different views

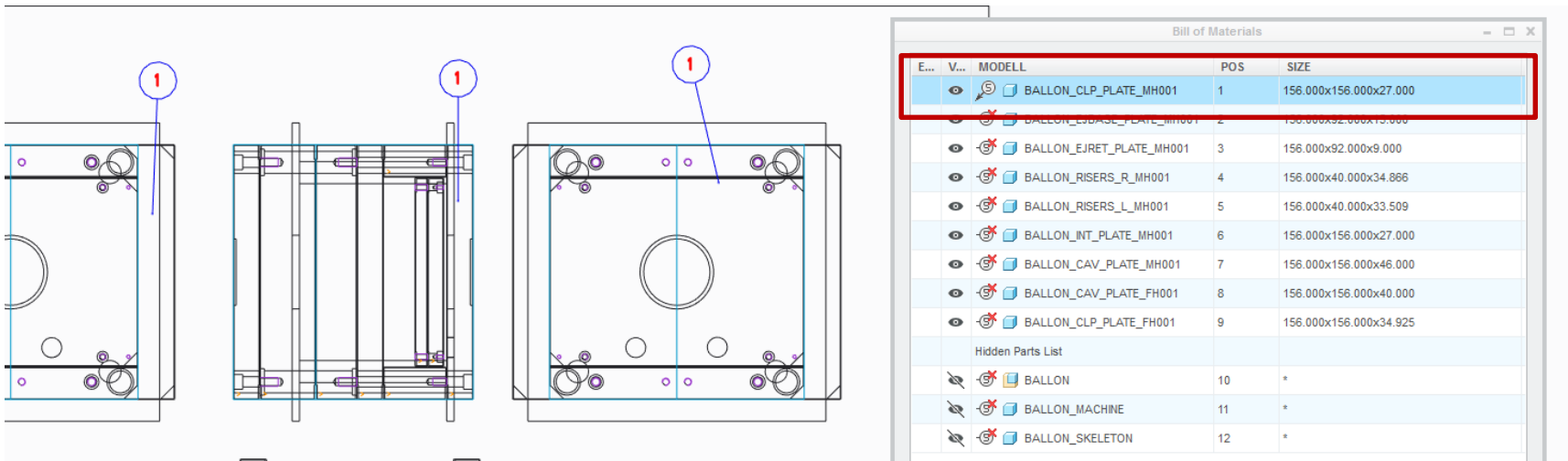



# 13. Enable Cell Colors in Comp Dialog

## Improvements

```
!listing of nominal dimensions
!NAME      DISPLAY_NAME  DIM_NAME  TYPE
EMX NOM_VALUES
E1200      diameter     DM1       PULLDOWN
E1200      length       LG1       PULLDOWN    >REF1
E1200      offset       OFFSET    EDIT
E1200      distance     REF1     DISABLED
E1200      color        COLOR    COLOR
EMX NOM_VALUES END
```

INSTANCE	ORD_NUMBER	USER_NUMBER	PRICE	COLOR
E1200_2_6	E1200/2x6	-	0	100,100,100
E1200_2_8	E1200/2x8	-	0	GREEN
E1200_2_10	E1200/2x10	-	0	RED
E1200_2_12	E1200/2x12	-	0	YELLOW
E1200_2_16	E1200/2x16	-	0	BLUE
E1200_2_20	E1200/2x20	-	0	ORANGE
E1200_2_5_12	E1200/2,5x12	-	0	RED
E1200_3_6	E1200/3x6	-	0	RED
E1200_3_8	E1200/3x8	-	0	RED
E1200_3_10	E1200/3x10	-	0	RED
E1200_3_12	E1200/3x12	-	0	RED
E1200_3_14	E1200/3x14	-	0	RED
E1200_3_16	E1200/3x16	-	0	RED
E1200_3_20	E1200/3x20	-	0	RED
E1200_3_25	E1200/3x25	-	0	RED
E1200_3_30	E1200/3x30	-	0	RED
E1200_3_35	E1200/3x35	-	0	RED
E1200_3_40	E1200/3x40	-	0	RED
E1200_4_6	E1200/4x6	-	0	RED
E1200_4_8	E1200/4x8	-	0	RED
E1200_4_10	E1200/4x10	-	0	RED
E1200_4_12	E1200/4x12	-	0	RED

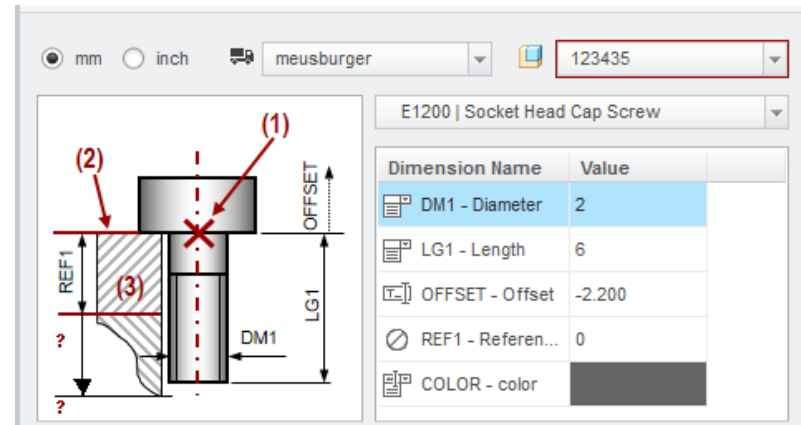
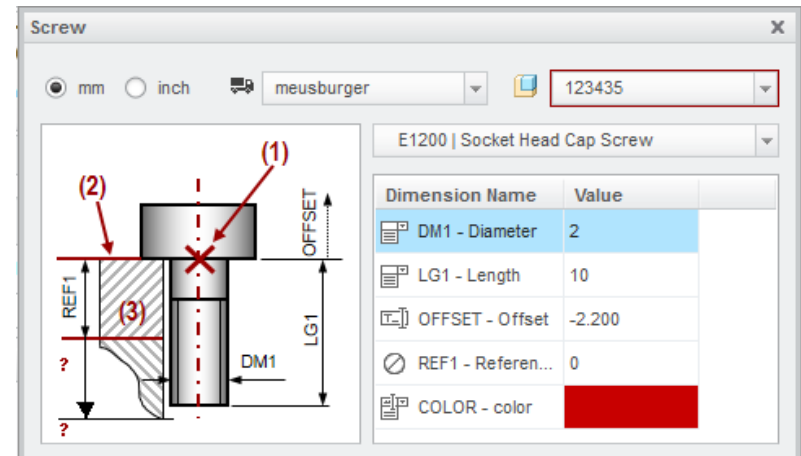

# 14. Add Relations to Post Regen Area

## Improvements

- Add Relations to Post Regeneration Area with specified files
1. emx\_comp\_post\_regen.rel
  2. plate\_post\_regen.rel
  3. etc.

Name	Änderungsdatum	Typ	Grö
emx_bom.xls	06.04.2016 09:44	Microsoft Excel 97...	
emx_bom_adv.xls	25.08.2016 13:28	Microsoft Excel 97...	
emx_comp.rel	09.09.2016 08:58	REL-Datei	
inactive_emx_comp.rel	06.04.2016 09:44	REL-Datei	
inactive_ref_feat_udf.gph	06.04.2016 09:44	Creo User defined ...	
insert_asm.asm	25.08.2016 13:28	Creo Assembly File	
insert_asm_inch.asm	06.04.2016 09:44	Creo Assembly File	
insert_comp.prt	06.04.2016 09:44	Creo Part File	
insert_comp_inch.prt	06.04.2016 09:44	Creo Part File	
view_layer_template_german.prt	25.08.2016 13:28	Creo Part File	
view_layer_template_usascii.prt	25.08.2016 13:28	Creo Part File	
emx_comp_post_regen.rel	09.09.2016 10:40	REL-Datei	

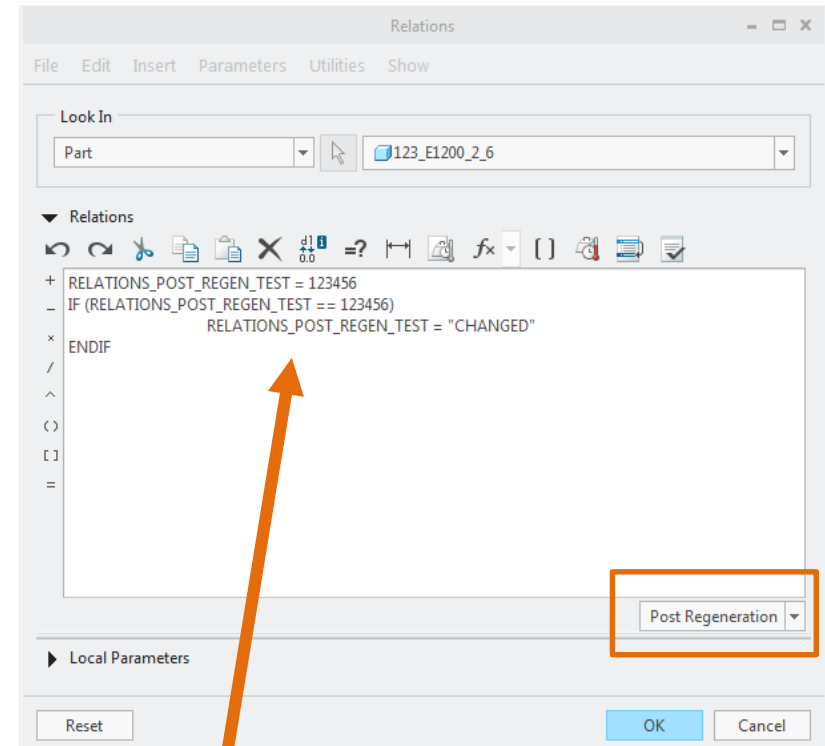

```

1 RELATIONS_POST_REGEN_TEST = 123456
2 IF (RELATIONS_POST_REGEN_TEST == 123456)
3     RELATIONS_POST_REGEN_TEST = "CHANGED"
4 ENDIF
    
```

## 15. Windchill Autonumber Renaming

---

### Improvements

- New Option WINDCHILL\_AUTONUMBER
- When working with Windchill and option is set to YES EMX uses next valid name in Windchill for renaming
- Windchill Common Name is set by standard naming mechanism defined in partnames.cfg
- Use keyword WINDCHILL\_AUTONUMBER as rule in partnames.cfg to apply auto renaming for individual components

## 16. Angular Cutouts for Guides and Screws

### Enhancement

Screws and Guides can now be placed on Axis/Points and Planes which are not orthogonal to each other.

→ Cutouts will be created with given angle.

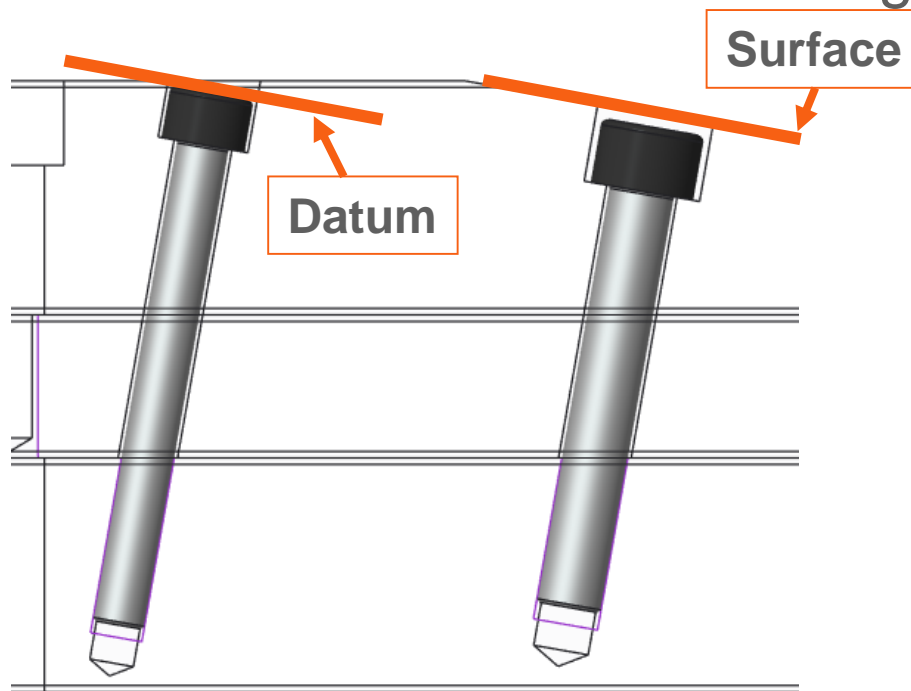

#### Note

Works with EMX standard configuration.

If you use a custom configuration following UDFs need to be added to custom config:

```

<emx_install>\components\mm\screw\udf
1. screw_straight_hole_coax.gph
2. screw_thread_bore_coax.gph
<emx_install>\components\mm\guides\udf
1. guide_straight_hole_coax.gph
2. guide_blind_hole_coax.gph
    
```

# 17. Ignore Subcomps of ASMs in BOM

## Enhancement

Purchased assemblies can be marked in BOM  
 → All subassemblies and sub components will be ignored in BOM

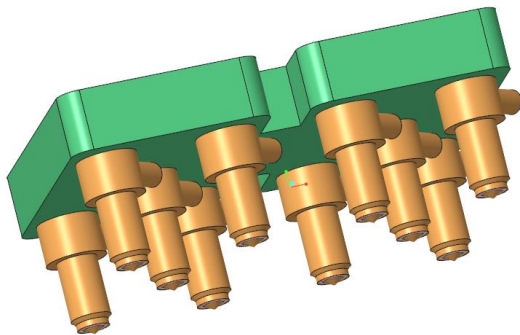

	HOT_12MATRIX001	20	
	HOT_12MATRIX001	21	
		123_BI-METALLIC_C-SPRUE002	22
		123_SEAL2002	23
		123_HOTSPRUE2	24
		123_SEAL1002	25
Hidden Parts List			
	HOTRUNNER	26	
	HOT_MACHINE	27	
	HOT_SKELETON	28	

Default: All parts and subassemblies are listed in BOM.

	HOT_E1010_22_56_75	17	
		HOT_E1100_24_76	18
		HOT_E1100_22_76	19
		HOT_12MATRIX001	20
Hidden Parts List			
	HOTRUNNER	21	
	HOT_MACHINE	22	
	HOT_SKELETON	23	

Mark assembly as purchased part with RMB functionality.



Status displayed with Icon.

## 18. Cut and Paste with Ctrl+X / Ctrl+V in BOM

### Enhancement

Cut and Paste can now be done with keyboard shortcuts  
Ctrl+X and Ctrl+V.

→ Quick repositioning of BOM entries.

		HOT_CAV_PLATE_FH001	9	1	HOT_CAV
		HOT_CLP_PLATE_FH001	10	1	HOT_CLP
		HOT_STOP_DISC			STO
		HOT_STOP_ASM			STO
		HOT_E1200_12_1			E120
		HOT_E1200_12_4			E120
		HOT_E1200_8_25			E120
		HOT E1010 24 56 75	16	3	HOT E101

Edit BOM Parameters

Cut

Paste

Show/Hide Items

Mark/Unmark a purchased Part/Assembly

# 19. Search Feature in BOM Dialog

## Enhancement

Search for Keywords in BOM to find entries.  
 Found entries are highlighted in list.

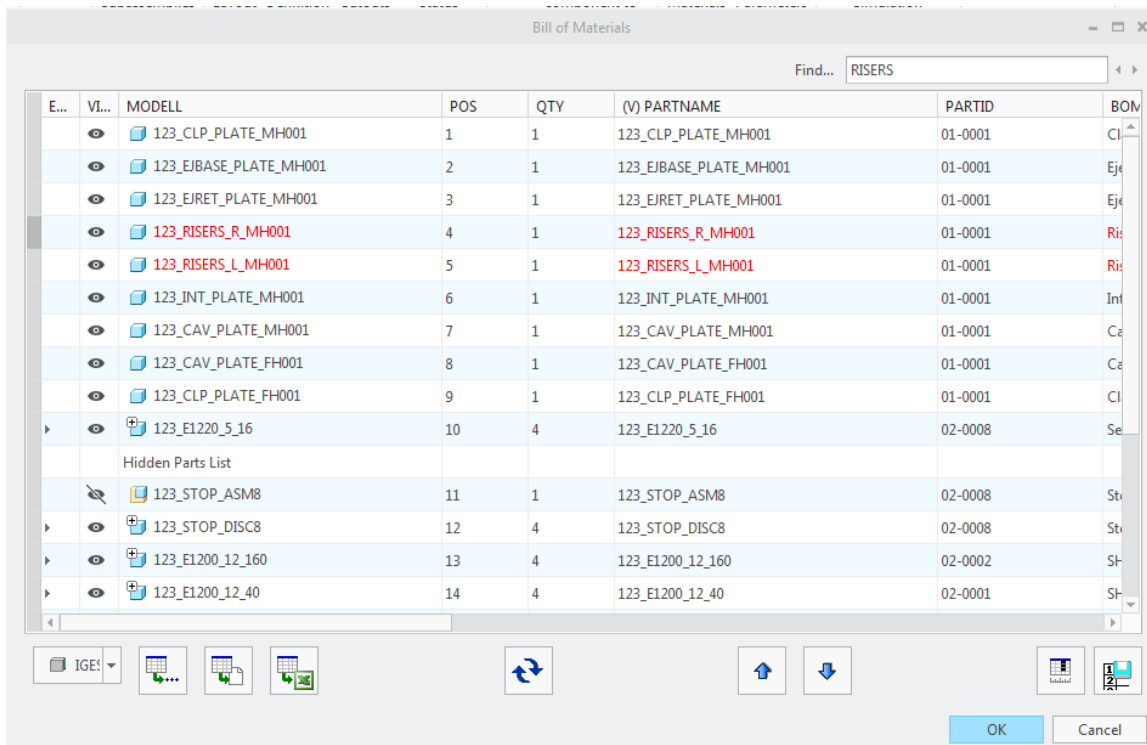

# EMX 10 F000

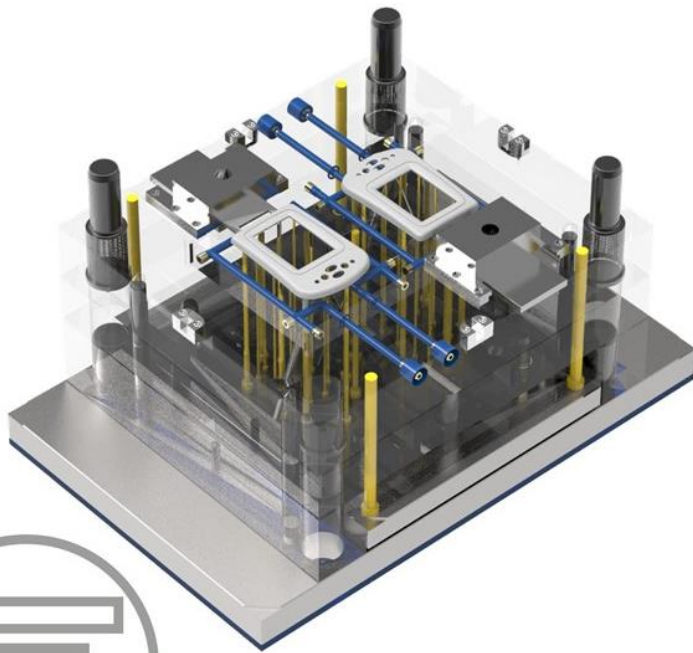

What's New?

- New Features
- Components





# Components

---

## New Components

- Misumi – Cooling NPW and M-KOC
  - Misumi – Top Lock TPN
  - Misumi – Flat Ejector Pin ESHJ, ERZF and ERVB
  - Meusburger – Guide E10025
  - Meusburger – Ejector Pin E10125 (DLC Coated)
  - Meusburger – Spring E1546
  - Hasco – Guide Z040
  - Hasco – Locating Ring K107, K501, K506, K1000
  - Knarr – Ejector Pin 37999
  - Strack - Z17, Z18 Locating Rings
  - Strack - Z45 side interlock components
- 
- A decorative graphic element consisting of a thick grey curved line with a thin orange line underneath it, located in the bottom right corner of the slide.

# Components

---

## New Components

- Meusburger – Guide E1032: Inclined Pin
  - Meusburger – Locating Ring E1362
  - Meusburger – Screw E1514: Threaded Bolt
  - Meusburger – Cooling E2800: Stäubli Connector
  - Knarr – Ejector Pin 36555
  - Knarr – Ejector Pin 36599
  - Knarr – Ejector Pin 37414
  - Knarr – Ejector Pin 37555
  - Knarr – Ejector Pin 37888
  - WEMA – Cooling S3102: Sealing Plug
  - WEMA – Cooling S3105: Diverting Plug
  - WEMA – Cooling S3111: Core Cooling Element
  - WEMA – Cooling S3113: Core Cooling Element
  - WEMA – Cooling S3115: Baffle Cooling Element
  - WEMA – Cooling S3117: Spiral Baffle Cooling Element
- 
- A decorative graphic element in the bottom right corner consisting of a thick grey curved line and a thinner orange curved line below it.

# Components

---

## Updated Components:

- Hasco – Locating Ring K100
  - Hasco - Side Interlock Z18/19
  - Hasco – Cooling O-Ring Z98
  - LKM – Side interlocks
  - Meusburger - Insulation Plates E1402 E1403 E1407 E1408
  - Meusburger – Top Interlock E1310
  - PCS – Ejector Pins: All Types Verify and Updated
  - PCS – Support Pillars
  - PCS – Locating Rings
  - Hasco – Locating Ring K100
  - Hasco - Side Interlock Z18/19
  - Hasco – Cooling O-Ring Z98
  - LKM – Side interlocks
  - Meusburger - Insulation Plates E1402 E1403 E1407 E1408
- 
- A decorative graphic element consisting of a thick grey curved line with a thin orange line underneath it, located in the bottom right corner of the slide.

# Components

---

## Updated Components:

- Misumi – Ejector Pins Type Verified
  - Meusburger - Ejectors E1712 add Rotation Fixtures option
  - Meusburger – Top Interlock E1310
  - PCS – Ejector Pins: All Types Verify and Updated
  - PCS – Support Pillars
  - PCS – Locating Rings
- 
- A decorative graphic element consisting of a thick grey curved line and a thin orange curved line, both curving upwards from the bottom right corner of the slide.

# Components

---

## Updated Plates:

- Futaba - Catalog – All sizes checked and updated
- Meusburger - Plates updated
- Meusburger - E2071 Add option Counter/Second Bore